



Featuring the
"Advanced Closed System +3"

ELECTRIC HEATED – Boilerless

Cooking Modes:

- Hot Air
- Retherm
- "Delta T" slow cooking
- Steam
- "Cook & Hold"
- "Crisp & Tasty"
- Combi

Cleveland Standard Features:

- "Advanced closed system" with "Crisp & Tasty" de-moisturizing feature
- Efficient heating system saves energy and provides fast heat up times
- Fully insulated cooking compartment for maximum energy savings
- Polished cooking compartment with coved corners for easy cleaning
- Six (6) 26" x 20" wire shelves
- Hinged fan guard and hinged removable pan racks
- Two (2) speed auto reversing convection fan for even heat distribution
- Space saving, easy to operate "Disappearing Door"
- "Antibacterial Hygenic Door Handle" with embedded silver ion protection
- Door latch with safety vent position and wear-free door switch
- Vented, double glass door with integrated door stop
- Trolley with self draining condensate drip tray
- Easy to change, press-fit door seal
- Oven light with shock resistant safety glass
- Multipoint core temperature probe
- Digital controls for temperature, time and core probe settings
- Self diagnostic system with full text message display
- Easy to understand menu icons with bright graphics display
- User friendly selector dial
- Exclusive "Smart Key" for selecting option settings
- Eight (8) "Press & Go" one step, recipe start buttons
- Cook book library for up to 250 stored recipe programs, each recipe capable of 20 steps
- Memory module for saving unit settings and recipes
- Smooth action hand shower for compartment cleaning
- Injection system for steam

Options and Accessories

- CONVOClean hands free automatic compartment washing system
- CONVOCControl software for establishing "HACCP controls" and automatic documentation of the cooking process
- Pan rack adapter to hold full size sheet pans without the use of wire shelves
- Lockable cover over operating controls for prison installations

MODEL: OES 12.20

CAPACITY: Twelve (12) - 18" by 26" by 1" full size sheet pans* or
 Twenty-four (24) - 13" by 18" by 1" half size sheet pans* or
 Twenty-four (24) - 12" x by 20" by 2 1/2" steam table pans
 *On wire racks. Additional wire racks required for maximum capacity.



Short Form Specifications

Shall be Cleveland Model: OES 12.20 Combination Convection Oven / Steamer with simple to operate programmable controls for Hot Air, Convection Steam, and Combination cooking modes, "Cook & Hold" and "Delta T" slow-cooking capabilities, "Advanced Closed System" with "Crisp & Tasty" de-moisturizing feature. Multiple cooking stage programs, stored recipe library, multipoint core temperature probe, "Press & Go", one-step recipe start buttons, "Smart Key" for selecting option settings, two (2) speed auto reversing convection fan, boilerless. "Disappearing Door" with "Antibacterial Hygenic Door Handle". Capacity for twelve (12) 18" x 26" full size sheet pans, or twenty-four (24) 12" x 20" x 2 1/2" pans.

- Ethernet connection for networking and controlling up to 100 units with a personal computer
- Pan rack with trolley
- Plate rack with trolley for banquet operations
- Thermal cover for plate or pan rack
- CONVOClean compartment cleaning solution
- CONVORinse compartment rinse cycle solution
- "Dissolve" generator descaling solution
- Chicken Grill Rack
- CONVOGrill Grilling Rack
- 12" x 20" Wire Baskets for frying products
- Additional 26" x 20" Wire Shelves
- Pre-heat bridge
- 480 volt option
- Kleensteam II Water Filters
- easyToUCH™ control panel

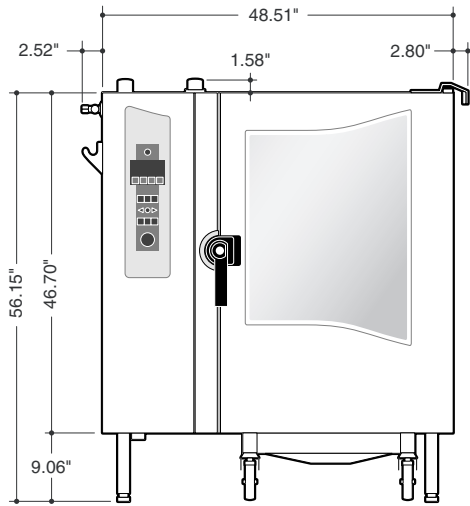

FRONT VIEW

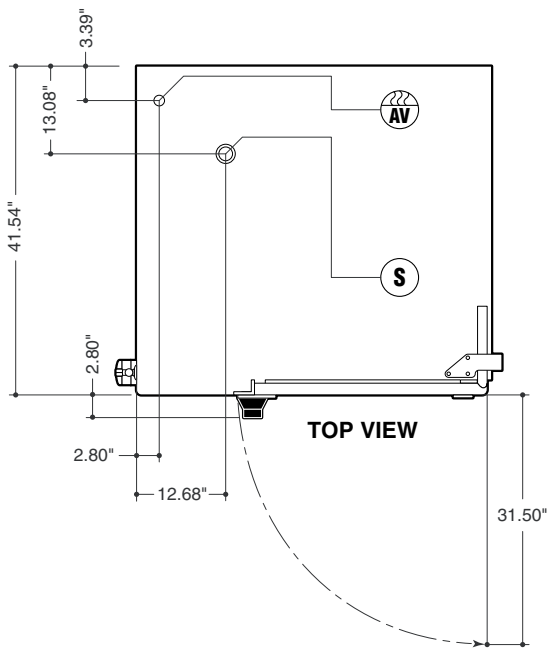

TOP VIEW

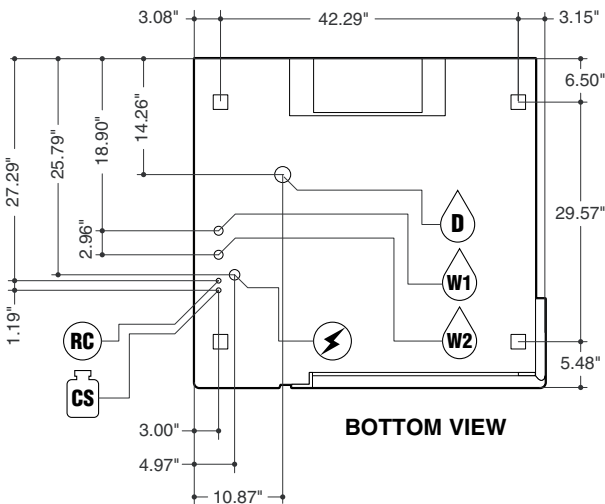

BOTTOM VIEW

NOTES:

Cleveland Range reserves right of design improvement or modification, as warranted.
 Many regional, state and local codes exist and it is the responsibility of the owner and installer to comply with the codes.
 Cleveland Range equipment is built to comply with applicable standards for manufacturers.

Model: OES 12.20

Pan Capacity [Unit (trolley) has 12 slide rails at 2.64" (67mm) apart]:
 12 (20" x 26") full size wire racks 12 (18" x 26") full size sheet pans - on wire racks
 24 (13" x 18") half size sheet pans - on wire racks 24 (12" x 20" x 2 1/2") steam table pans
 24 (12" x 20" x 1") steam table pans 24 (12" x 20") frying baskets - (no wire racks needed)

For Banquet Operations: Optional Plate Rack holds 74 plates

Unit Dimensions: Width - 53.83", Depth - 44.34", Height - 57.73"

Shipping Dimensions: Width - 60", Depth - 50", Height - 66"
 (including packaging)

Shipping Weight: 717 Lbs (including trolley)

Required Clearances: Rear - 2", Left Side - 4", Right Side - 2 1/2"
 • Allow for sufficient distance if a "high heat source" (i.e. Broiler) is located next to the unit.
 • Allow for sufficient clearance on left side for service access (contact the factory service department for recommendations).
 • Installation must comply with all local fire and health codes.

Agency Approvals: UL, UL - Sanitation (NSF Standards)

⚡	Electrical Requirements:	208/3/60	240/3/60	440/3/60	480/3/60
	Total Connected Load:	26.3 KW	34.9 KW	29.4 KW	34.9 KW
	Hot Air:	25.8 KW	34.3 KW	28.8 KW	34.3 KW
	Amps per Phase:	77.8	88.8	41.4	44.9

Do not connect to a G.F.I. outlet

Water Connections: Cold Water (drinking water quality)
 Dynamic Pressure: 35 - 60 PSI
 Water Inlets: 3/4" GHT-F (Female Garden Hose Connection)

- Treated Water for Steam Production
- Untreated Water for Condenser and Hand Shower

NOTE:
 The owner / operator / purchaser must ensure that the Water Quality Requirements are met. Not meeting the water quality requirements will void the original equipment warranty.

Water Quality Requirements:

TDS	< 60 ppm	pH Factor	7.0 – 8.5
Total Alkalinity	< 20 ppm	Free Chlorine	< 0.1 ppm
Silica	< 13 ppm	Conductivity	min. 20 µS/cm (50 kOhms)
Chloride	< 25 ppm		

Drain Connection: 2" Tube

Venting: Exhaust Hood required

Air Vent

***Connection for Cleaning Solution**

***Connection for Rinse Cycle**

Low Pressure Safety Valve

*Available as an option